

Marathon Power Technologies Company

Nickel-Cadmium Aircraft Batteries

Model BTSP - 400 Replacement Parts

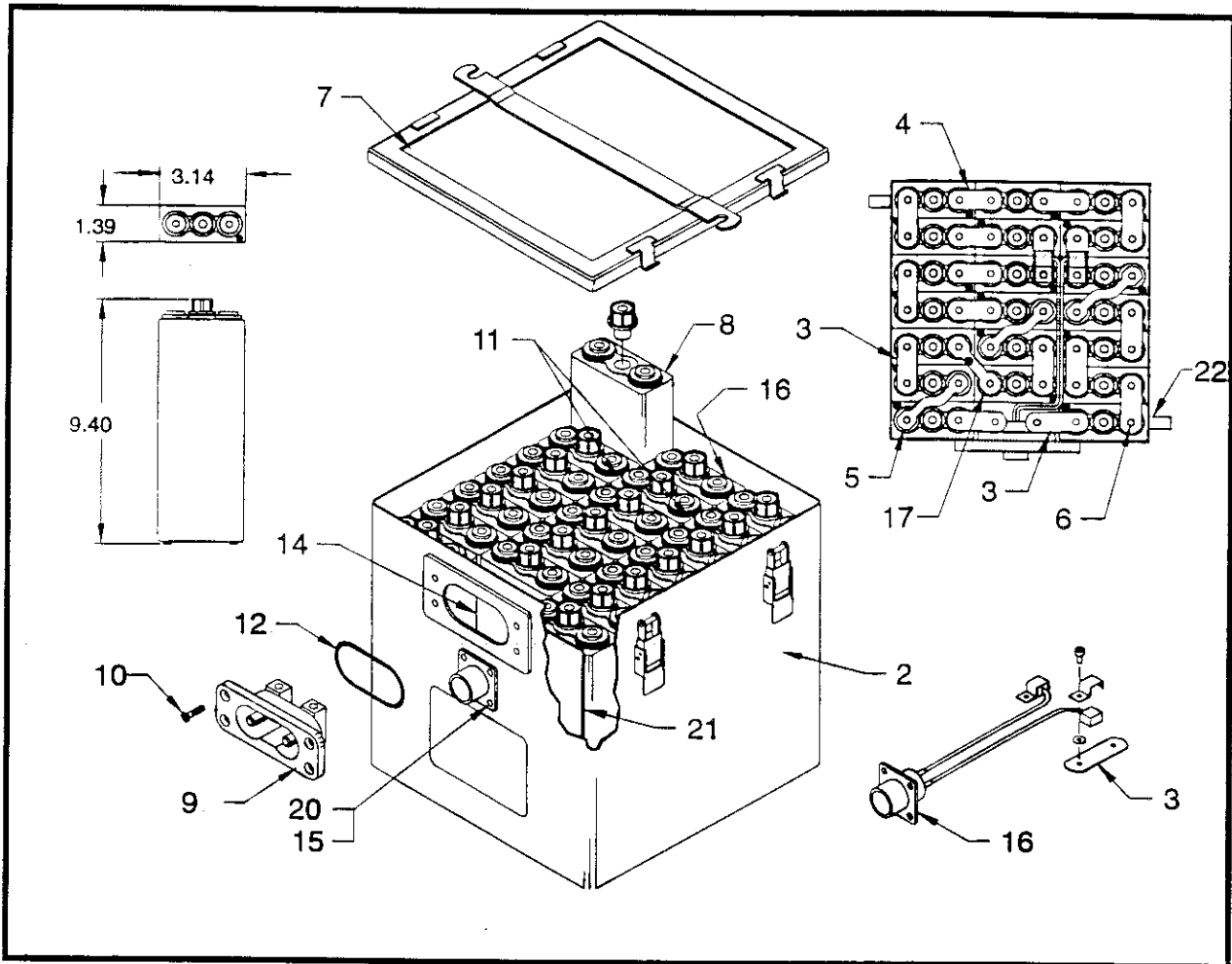

ITEM	DESCRIPTION	PART NUMBER	QTY
1	BATTERY, BTSP-400	30441-001	1
2	CAN, MARKED	40247-001	1
3	CONNECTOR	16102-135	12
4	CONNECTOR	16102-136	5
5	CONNECTOR	16167-006	3
6	SCREW	30877-002	42
7	COVER, MARKED	40062-001	1
8	CELL 40SP100	30114-01C	20
9	ASSEMBLY, RECEPTACLE	16163-023	1
10	SCREW	23084-001	4
11	SHIM, MIDDLE	9988-232	2

ITEM	DESCRIPTION	PART NUMBER	QTY
12	RING, RECTANGULAR	24583-001	1
13	SENSOR & CLAMP	29529-001	1
14	SPACER	27291-004	1
15	WASHER, LOCK	6560-006	4
16	SHIM	9988-047	4
17	CONNECTOR	16167-007	1
18	SPRING, SHORTING	25908-001	1
19	CLOSURE, PROTECTIVE	26916-004	1
20	SCREW, FILLISTER HD.	15940-028	4
21	SHIM	9988-174	3
22	DUST CAP	16065-012	2



Marathon Power Technologies Company

Hi011696

Battery Products

P.O. Box 8233, Waco, Texas 76714

8301 Imperial Drive, Waco, Texas 76712

TEL (817) 776-0650 FAX (817) 776-6558