

# Marathon Batteries

## Sintered-Plate Nickel-Cadmium Aircraft Batteries

Parts List

CA-106  
TCA-106

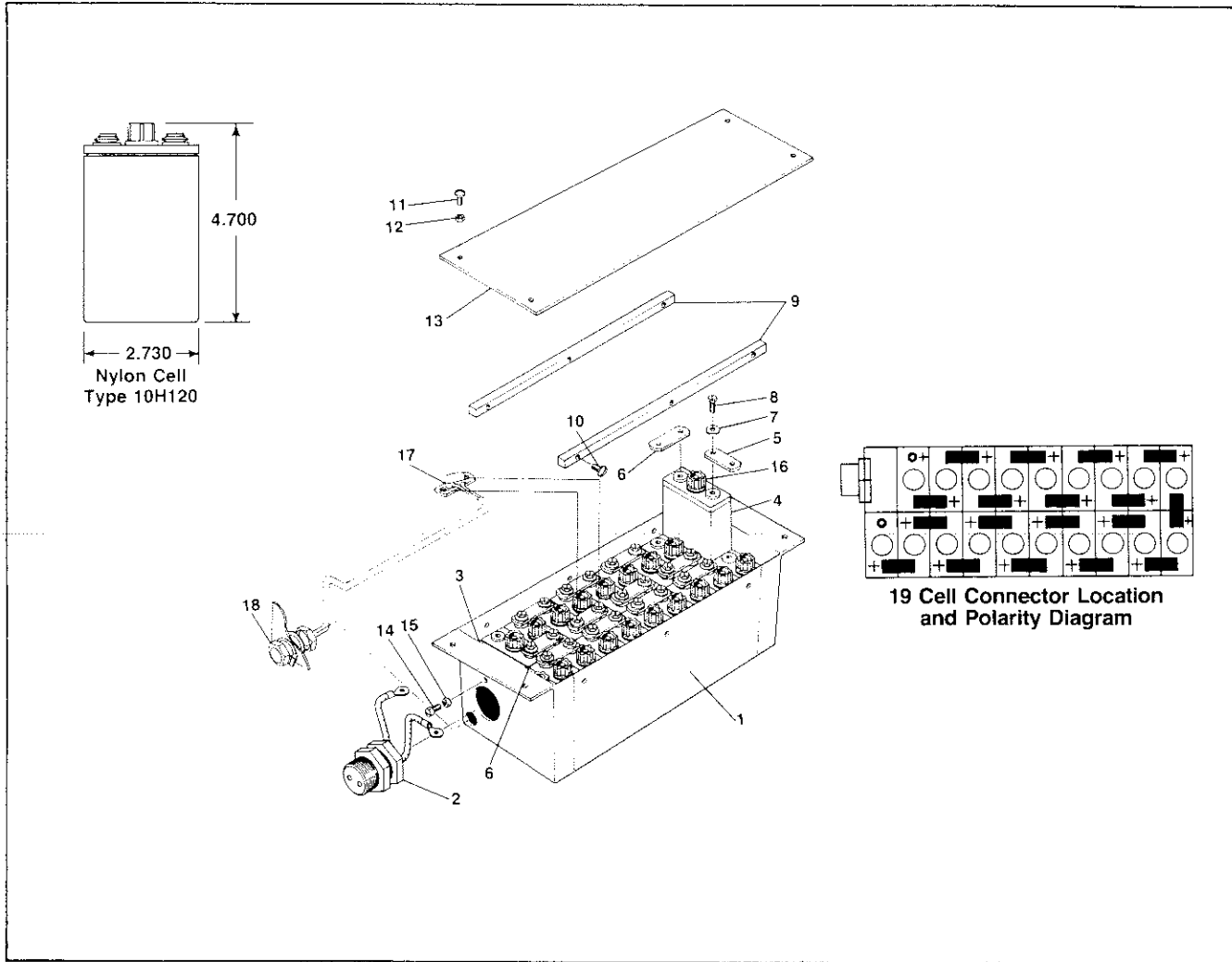

### Model CA-106 TCA-106 Battery Replacement Parts

Item	Description	Part Number	Quantity	Part Number	Quantity	Item	Description	Part Number	Quantity	Part Number	Quantity
		CA-106		TCA-106				CA-106		TCA-106	
1	Battery Box	28100-1	1	28100-4	1	10	Machine Bind Head Screw	9954-18	6	9954-18	6
2	Receptacle Assembly	28129-1	1	28129-1	1	11	Machine Rd. Head Screw	8973-46	4	8973-46	4
3	Spacer	27679	1	27679	1	12	Hex #10-32 Nut	15111-58	4	15111-58	4
4	Cell Assembly	10H120	19	10H120	19	13	Cover Assembly	28101-1	1	28101-3	1
5	Connector	10371-114	18	10371-114	17	14	10-32 Drilled Filler Screw Hd. Slot'd	28171	1	28171	1
6	Barrier	27861	1	27861	1	15	Nut Hex Esna Type #10-32	15013-4	1	15013-4	1
7	Belleville Spring Slotted Hex Head Screw	16128-26	38	16128-26	38	16	Filler Cap & Vent Assembly	16934-1	19	16934-1	19
8	Socket Head Cap Screw	25635-1	38	—	—	17	Temperature Switch Harness Assy.	—	—	29170-1	1
9	Hold Down Strip	28120	2	28120	2	18	Miniature Connector	—	—	29145	1

**marathon battery company**

8301 IMPERIAL DRIVE • P. O. BOX 8233 • WACO, TEXAS 76710

A DIVISION OF MARATHON MANUFACTURING COMPANY • HOUSTON, TEXAS 77002