

# Marathon Batteries

## Sintered-Plate Nickel-Cadmium Aircraft Batteries

Parts List

CA-91-20

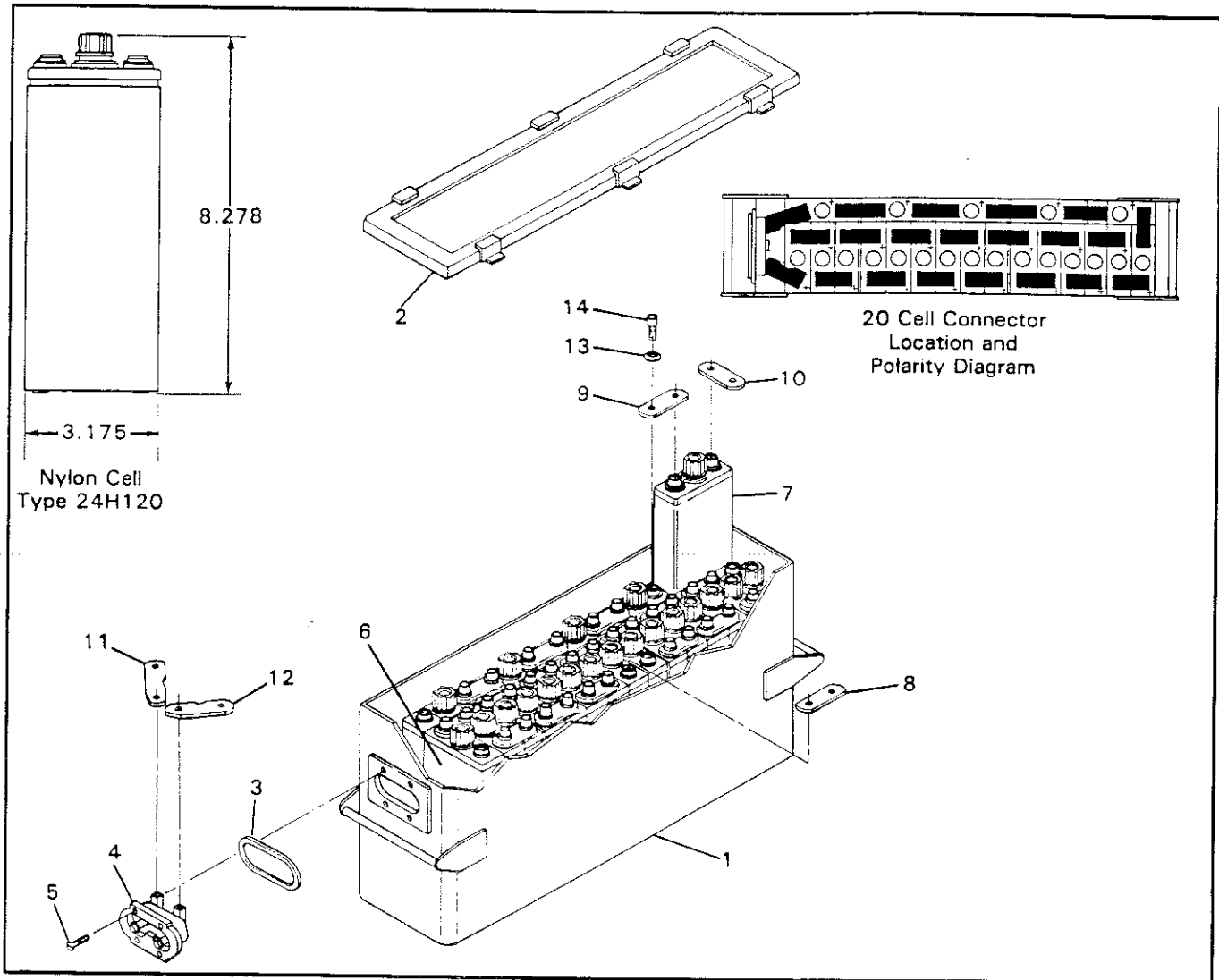

### Model CA-91-20 Battery Replacement

Item Description	Part Number	Qty	Item Description	Part Number	Qty
1 Can Assembly	D29223-000	1	8 Connector	D16102-052	12
2 Cover Assembly	C29222-000	1	9 Connector	D16102-138	4
3 Gasket, Receptacle	B24583-001	1	10 Connector	D16102-007	3
4 Receptacle Assembly	C27904-003	1	11 Connector	B29232-001	1
5 Screw, Flat Head	B23084-001	4	12 Connector	B29232-002	1
6 Spacer	C29003-004	1	13 Belleville Spring	C16128-001	42
7 Cell Assembly O/L 24H120	C16962-009	20	14 Screw, Soc. HD Cap	C10488-020	42



8301 IMPERIAL DRIVE • P.O. BOX 8233 • WACO, TEXAS 76710  
DIVISION OF MARATHON MANUFACTURING COMPANY • HOUSTON, TEXAS 77002